

# C E M I N T E L<sup>®</sup>



SURROUND<sup>®</sup> SERIES  
Internal Installation

## TABLE OF CONTENTS

<b>01 INTRODUCTION</b>	<b>2</b>	<b>06 SYSTEM ENGINEERING</b>	<b>17</b>
Introduction	2	Design, Detailing and Performance	
<b>02 PRODUCT OVERVIEW</b>	<b>3</b>	Responsibilities	18
Panel Information	4	Wind Loads	18
Colour Palette	5	<b>07 INSTALLATION</b>	<b>19</b>
<b>03 SYSTEM OVERVIEW</b>	<b>6</b>	<b>Fixing Option 1</b>	<b>20</b>
Installation Method – Options	7	Concealed Fixing – Adhesive to Timber Stud	
Applications	8	<b>Fixing Option 2</b>	<b>23</b>
Benefits of the Cemintel Surround System	8	Concealed Fixing – Adhesive to Steel Stud	
Product Specifications/System Solutions	8	<b>Fixing Option 3</b>	<b>27</b>
<b>04 DESIGN + AESTHETIC CONSIDERATIONS</b>	<b>9</b>	Concealed Fixing – Timber Battens For Retrofit Over Existing Linings	
General	10	<b>Fixing Option 4</b>	<b>30</b>
Internal Wind Pressures	10	Concealed Fixing – Timber/MDF Split Battens	
Control Joints	10	<b>Fixing Option 5</b>	<b>33</b>
Structural	10	Exposed Fixing – Rivet To Steel Framing	
Panel Layout	11	<b>08 CONSTRUCTION DRAWINGS + DETAILS</b>	<b>36</b>
Other Design Considerations	11	<b>09 SAFETY, HANDLING, GENERAL CARE + WARRANTY</b>	<b>40</b>
Inspection, Repair and Maintenance	12	Health, Safety and PPE	41
Cleaning	12	Safety, Handling, and Maintenance	41
<b>05 COMPONENTS + ACCESSORIES</b>	<b>13</b>	Warranty	41

## Introduction

Cemintel's Surround Internal walling system combines a prefinished surface with a simple installation system. Surround can be installed either horizontally or vertically, externally or internally.

This Design and Installation Guide recommends good building practice methodology and has been prepared as a general guide on design considerations, system engineering information and installation procedures for **common internal applications**. It assumes that the user has an intermediate knowledge level of building design and construction. In no way does it replace the services of the building professionals required to design projects,

nor is it an exhaustive guide of all possible scenarios. It is the responsibility of the architect, designer and various engineering parties to ensure that the details in this Design and Installation Guide are appropriate for the intended application.

Refer to the 'Design and Installation Guide for Cemintel Surround External Installation' for instructions regarding external applications.

Surround panels can also be used in ceiling/soffit applications. For fixing details, please contact **DesignLink on 1800 621 117**.



# 022

PRODUCT OVERVIEW

## 02

## PRODUCT OVERVIEW

**Panel Information**

Cemintel Surround panels are prefinished, fibre cement panels that are colour bodied delivering a more natural appearance and depth of colour than can be achieved with a standard surface painted finish. They come trimmed and sealed in a standard 1200x3000x8mm size\* and are factory coated on both sides with a polyacrylic coating.

Consisting primarily of Portland Cement, wood pulp, reinforcement fibres, air and water, the panels have undergone a longer, natural air curing process. They offer superior performance in terms of strength, density and durability, making them an excellent choice for internal applications requiring a higher level of impact resistance.

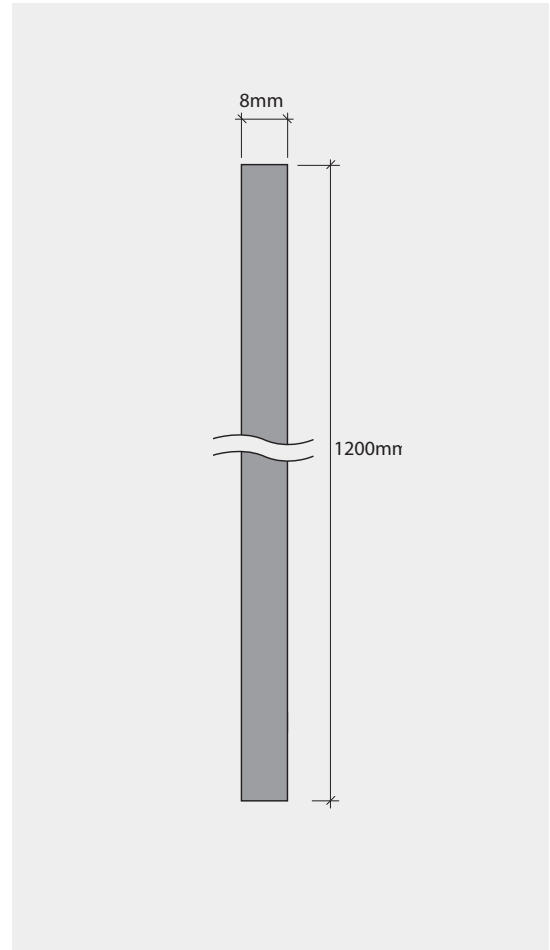

Surround Blackish Marl

**Colour Palette**

As Surround is a prefinished product, product images may vary from the actual product in regard to colour and surface finish.

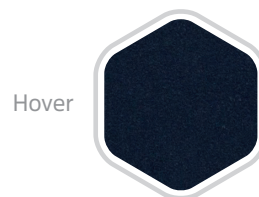

# 03

SYSTEM OVERVIEW

## SYSTEM OVERVIEW



This Design and Installation Guide outlines a system solution for installing Surround as an internal wall lining in dry areas.

Surround panels can be fixed to timber or non-structural light gauge steel framing, and can also be fixed to masonry, concrete or autoclaved aerated concrete substrates via timber/MDF battens or metal furring channels.

Panels can be installed in a number of different ways, using concealed fixing methods or exposed fasteners.

Panels are express jointed to give a clean, contemporary look. A closed cell, self adhesive decorative black tape is placed behind vertical joints. Depending on method of installation, the closed cell tape or a black metal backing strip is placed behind horizontal joints.

### Installation Method – Options

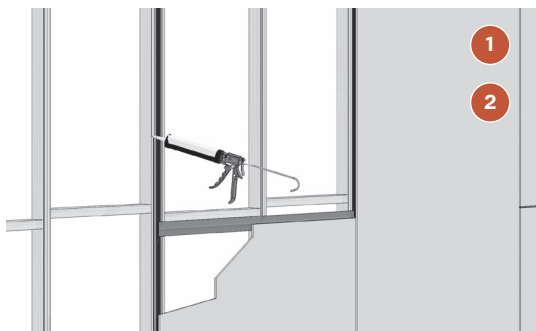

#### 1. Concealed Fixing – Adhesive to Timber Stud

This system involves using SIKA adhesive products to directly fix panels to timber framing.

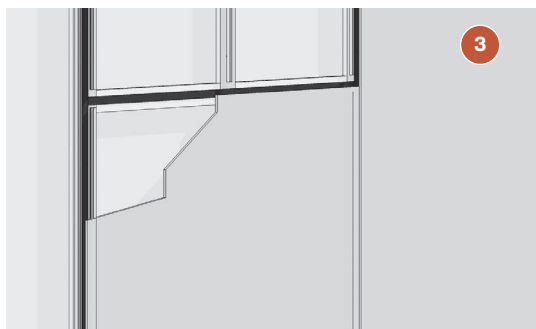

#### 2. Concealed Fixing – Adhesive to Steel Stud

This system involves using SIKA adhesive products to directly fix panels to steel framing.

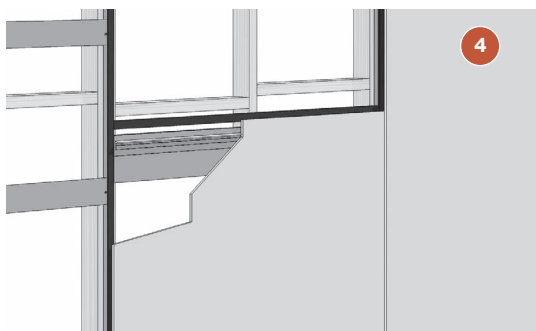

#### 3. Concealed Fixing – Timber Battens For Retrofit Over Existing Linings

Timber battens are installed over existing linings and panels are then fixed to battens using SIKA adhesive products. This provides a good solution for renovations and fitouts.



#### 4. Concealed Fixing – Timber/MDF Split Battens

Surround panels are fixed to MDF battens and installed onto a split batten system. This allows for easy panel removal (important where access to services is required).

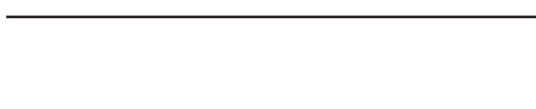

#### 5. Exposed Fasteners – Rivets to Steel Framing

Panels are directly fixed to steel studs using unique, colour matched Surround rivets. The unique Surround rivet allows a subtle “sliding” movement across the panel which reduces the stress on the panel due to internal movement.

Panels can be installed horizontally or vertically in a staggered or aligned grid pattern.

## 03

## SYSTEM OVERVIEW



## Applications

Surround offers a clean, contemporary feature wall solution for all building types.

## Benefits of the Cemintel Surround System

- Low maintenance.
- No requirement for additional painting costs.
- Potential to speed up the construction process.
- Large format panels, colour bodied.
- Strong and durable – suitable for heavy duty environments.
- Can be installed by concealed or exposed fixing methods.
- The unique Surround colour matched rivet with pre-assembled rubber sleeve allows slight movement across the panel thereby reducing the stresses created where panels are installed with “fixed” points.
- Purpose designed drilling, centring and rivet tools allow for fast and accurate preparation and installation.
- Panels are easy to cut for openings e.g. around windows and power boxes.
- Fire resistance – fibre cement sheets can be used where “non-combustible material” is required under the NCC deemed to satisfy provisions.



## Product Specifications/System Solutions

A technical Data Sheet can be downloaded from [cemintel.com.au](http://cemintel.com.au)

Dimensional/Geometrical Characteristic	Specification (trimmed panel)	Manufacturing Tolerance	Relevant Standard
Surround is manufactured in Europe to comply with the requirements of EN 12467 Fibre Cement Flat Sheets. It is classified as a Category A, Class 4 product.			
Panel Width	1200mm	+1.5mm / -1.5mm	EN 12467
Panel Length	3000mm*	+1.5mm / -1.5mm	EN 12467
Panel Thickness	8mm	+0.8mm / -0.8mm	EN 12467
Panel Mass (EMC)	15.7kg/m <sup>2</sup>		
Fire Resistance Properties			
Combustibility	Classified as a “non-combustible material” under the NCC deemed to satisfy provisions.		Volume One of NCC 2022 C2D10 [2019: C1.9]
Classification	Class A2-S1		EN 13501-1
Surface Burning Characteristics	Early Fire Hazard Indices are – Ignitability Index = 0 Spread-of-Flame Index = 0 Heat Evolved Index = 0 Smoke-Developed Index = 2 (Black), = 3 (White)		AS/NZS 1530.3
Fire Hazard Properties	Group Number = 1 Average Specific Extinction Area <250m <sup>2</sup> /kg SMOGRA <sub>RC</sub> = 0.2		AS ISO 9705 AS 5637.1
Apparent Thermal Conductivity	0.3785-1.0 +/- 6.5% W/(m.K)		ASTM C518

\*Lengths up to 3050mm are available as special orders.



A large, stylized number '04' is rendered in white with a thick outline. The '0' is a simple oval shape, and the '4' is composed of three distinct strokes: a diagonal line from top-left to bottom-right, a vertical line from top-right to bottom-right, and a horizontal line at the bottom. The number is positioned in the lower right quadrant of the page.

# 04

DESIGN + AESTHETIC  
CONSIDERATIONS



## DESIGN + AESTHETIC CONSIDERATIONS

**This section outlines some important areas for consideration in determining whether Cemintel Surround is suitable for the required application. The following points are not exhaustive. It is the responsibility of the Architect/Building Designer to ensure the design conforms to NCC requirements and other relevant building standards that may exist for that location. This guide should be read in conjunction with the NCC.**

### Internal Wind Pressures

Panels and framing are required to resist internal wind loads that are specific to the building site. It is recommended that the Architect/Building Designer assigns the responsibility for the internal linings to the project engineer. Guidance on allowable internal wind pressures for the various installation system options outlined in this manual is provided in the 'System Engineering' section of this guide.

### Control Joints

Panel Control joints should be installed to coincide with control joints in the supporting frame and where there are changes of substrate.

When installing Surround onto steel framing, a horizontal control joint is required at every slab junction to accommodate any deflection and discontinuity in the support framing. The Surround Internal panels should not span across ("bridge") movement joints in the structure. The magnitude of the deflection must be verified by the project engineer.

### Structural

#### Framing and Substrate Options

For timber and steel framing, the minimum requirement shall be in accordance with the following standards:

- AS 1684 – Residential Timber-Framed Construction.
- AS/NZS 4600 – Cold-Formed Steel Structures or AS 3623 Domestic Metal Framing.

Note that Surround panels must not be fixed to wet framing / unseasoned timber as this can cause excessive timber shrinkage and cause Surround lining to move.

Cemintel provides stud selection tables for steel studs in the 'System Engineering' section of this guide.

For Masonry, concrete or autoclaved aerated concrete substrates, furring channels must be installed.

### Frame Tolerances

It is critical that the frame is true and plumb. Any warping of the frame may still be visible after the internal lining is applied.

A suggested maximum tolerance of 5mm mis-alignment over 3000mm length is recommended.

### Battens

Installation methods 3 and 4 (refer to System Overview Section), require battens of 18mm thickness. Two batten widths are used. For sheet joints, a 92mmx18mm batten is used. At intermediate fixing points, a 66mmx18mm batten is used. Battens are to be fixed vertically to stud framing.

### Masonry/Concrete

Battens allow for correction of irregular surfaces. They are also a solution where the existing wall surface is not suitable for adhesive fixing due to flaking paint, drummy render etc.

Timber/MDF battens are either fixed directly to walls, or alternatively metal furring channel anchor clips can be used. These are attached to the wall prior to fitting the metal furring channels.

Use suitable masonry fasteners to securely fix timber/MDF battens or metal furring channels.

The spacing and fixing of anchor clips must be in accordance with the manufacturer's recommendations.

Pack behind battens as required to achieve a flat surface.

Support the Surround edges along the top and bottom of the wall.

### Curved Walls

Surround may be bent to a minimum radius of 10 metres to accommodate convex and concave curved walls. The framing must be set out to enhance appearance and avoid over-stressing the sheet and fixings. Where curved walls are installed, Surround panels must be rivet fixed.

## DESIGN + AESTHETIC CONSIDERATIONS



### Panel Layout

Surround panels can be installed horizontally or vertically onto the structural framework either in a grid or staggered layout.

The vertical joints between panels must be supported by double studs (with a total width of 70mm minimum). Horizontal panel joints need to be backed in accordance with the fixing system chosen (eg backing strip or batten with decorative tape).

When installing to timber or steel framing, the lower edge of bottom panels should be a minimum 6mm clear of the finished floor. Refer to Base Details in Construction Details/Drawings Section.

### Other Design Considerations

#### Exposed Fasteners

Only Surround rivets, with their unique rubber sleeve, can be used as mechanical fasteners for Surround panels to metal framing. These rivets allow a slight movement across the whole panel thereby reducing the stresses created where panels are installed with “fixed” points. Note: Use of standard rivets and gun heads is NOT ACCEPTABLE. Refer to installation instructions for further details

#### Concealed Fixing

It is important to ensure the substrate is properly prepared and is clean, dry and free of any material that will reduce the effectiveness of the adhesive bond (e.g. dust, loose paint/render, waterproofing etc). Refer to ‘Installation Instructions’ for further details.

#### Services

The Surround system will accommodate services that are run through the framing. Any notches or holes formed must be considered in the framing design.

#### Renovations

When undertaking building renovations, remove all lining from the original wall framing, unless utilising the Retrofit (Batten) installation method. Ensure the condition of the framing is in accordance with current requirements and is as true and plumb as possible (within accepted industry tolerance of 5mm misalignment over 3000mm). Install additional framing as required.

#### Limitations

Surround panels are not recommended and not warranted for the following applications –

- Wet areas such as bathrooms, pools, water features.
- Fireplace cladding.
- Exposure to temperatures greater than 50°C.
- As a substrate for tiles or other materials to the face of the panel.
- The panel being painted.

The above listing is not intended to be comprehensive. If in doubt, please contact Cemintel.

**FIGURE 4.01** Horizontal Sheeting Aligned Grid Pattern

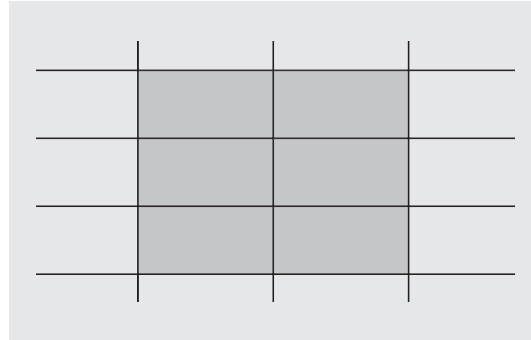

**FIGURE 4.02** Vertical Sheeting Half-Bond Pattern

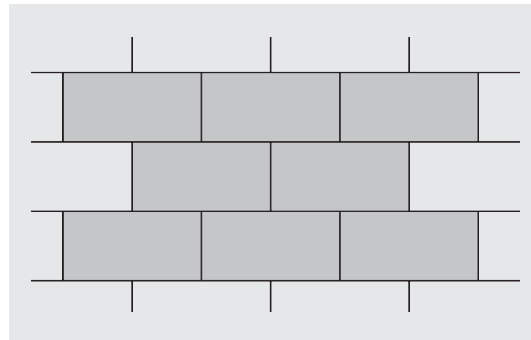

**FIGURE 4.03** Vertical Sheeting Aligned Grid Pattern

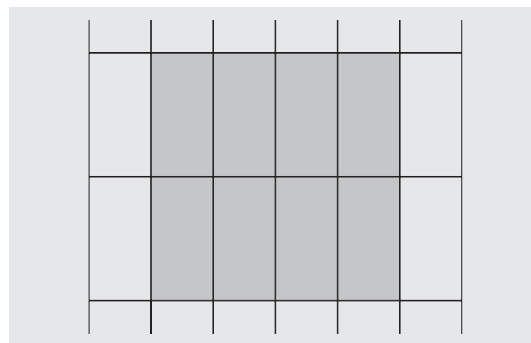

**FIGURE 4.04** Vertical Sheeting Half-Bond Pattern

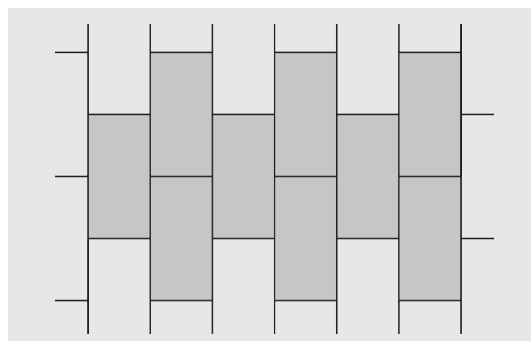

### Inspection, Repair and Maintenance

Regularly inspect panel surfaces and follow cleaning procedures when required.

It is recommended storing additional panels in case any panels are damaged in the future.

If a panel needs to be removed and replaced the following steps should be followed -

#### Concealed Fix options

Cut the centre of the panel to expose the tape and adhesive beads. These can then be cut using a suitable tool and the remainder of the panel removed. (refer to Figure 4.05 Panel Cutting). Caution - take care when cutting, check for services in the wall and ensure a minimal cut depth is used.

**FIGURE 4.05** Panel cutting

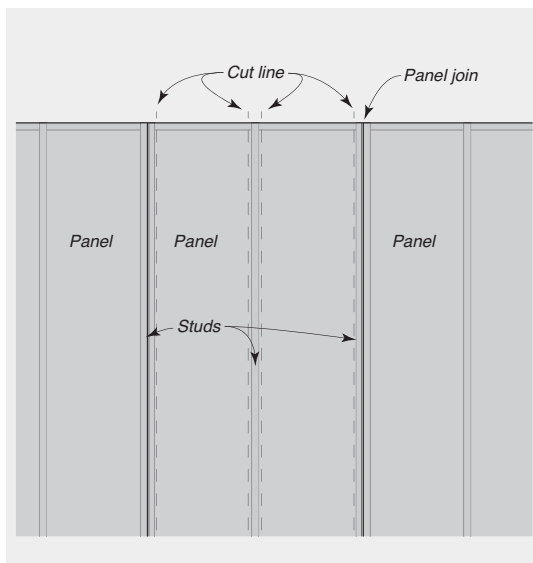

#### Rivet Fix options

Remove rivets and take out panel. Install replacement panel taking care not to install rivets in previous rivet holes.

### Cleaning

Surround panels have a polyacrylic coating which enables the surface of the panel to repel liquids such as coffee, red wine, sauces and tea.

To minimise absorption, any spills should be cleaned up immediately using the following process -

1. Do not wipe, rub or scrub as this may mark the surface or spread the spill.
2. If the spill is liquid, blot immediately with dry, absorbent paper towel or cloth.
3. If colour or liquid residue is left after Step 2 or the liquid has dried or evaporated, dab the area with a clean damp cloth, using only water.
4. If colour or liquid residue remains, use a PH neutral cleaning product, again dabbing the area, then remove the cleaner with a damp cloth. Allow the surface to dry.

# 05

COMPONENTS + ACCESSORIES

## 05

## COMPONENTS + ACCESSORIES

Note: Codes can change from time to time. Refer to the website for the current list of components prior to ordering.

**Cemintel Surround Panels and Coloured Accessories**

Description	Panel Code	Coloured Rivet
BLUEISH Base	162666	162687
BLACKISH Base	162667	162689
GREYISH Base	162669	162686
WHITEISH Base	162670	162644
HUSK	167452	167474
BLACKOUT	193015	193022
MAINLAND	167472	167484
QUINTA	193016	193023
HOVER	193017	193024
MAYA	167453	167475
GREENBACK	167455	167477
TRUSS GREY	167459	167481









## COMPONENTS + ACCESSORIES

05

Note: Codes can change from time to time. Refer to the website for the current list of components prior to ordering.

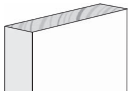
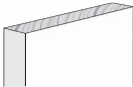
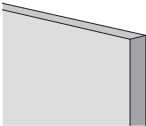
## Other Accessories/Tools for Installing Surround

\* **Fixing System Options** 1 = direct adhesive to timber stud 2 = direct adhesive to steel stud 3 = timber battens (retrofit)  
4 = split timber/MDF battens 5 = rivet to steel stud





Other Accessories	Description	Size	Product Code	Fixing System Option*
	<b>Batten Fixing Nails</b> – Machine driven D-head, class3. Used to fix timber/MDF battens to timber framing.	2.80 x 50mm (Box of 3000)	127799	3,4
	<b>Batten Fixing Screws</b> – Class 3, countersunk ribbed head, Phillips drive, treated pine screw. Used to fix timber/MDF battens to timber framing.	8G-10 x 50mm (Box of 1000)	127801	3,4
	<b>Batten Fixing Screws</b> – Otter (SLEG+), countersunk ribbed head, Phillips drive, class 3, treated pine screw. Used to fix timber/MDF battens to steel framing or furring channels of 0.50mm to 1.15mm BMT.	8G x 32mm	139844	3,4
	<b>Masonry Anchors</b> – used to fix furring channels to masonry, concrete and AAC. Must be suitable for substrate (refer to manufacturer for product and installation advice).		Supplied by others	
	<b>Surround Rivet</b> – for fixing Surround panels to steel framing or furring channels. Each rivet comes with an already assembled EPDM (TPS-SEBS) gasket. Rivet heads are colour matched to the panel. Rivets are manufactured from stainless steel consisting of V4A (equivalent to 316 grade) stainless steel mandrels and V2A (equivalent to 304 grade) stainless steel sleeves. Note: Use only the Cemintel Rivet and Rivet Gun Head. Standard rivets and gun heads are NOT ACCEPTABLE.	100 per pack	See previous page for codes	5
	<b>Timber Batten 18mmx66mm</b> – For use when using concealed fixing (timber batten) method. Fix vertically to intermediate studs.	18mm x 66mm	Others	3
	<b>Timber Batten 18mmx92mm</b> – For use when using concealed fixing (timber batten) method. Fix vertically to double studs at sheet joints.	18mm x 92mm	Others	3
	<b>MDF</b> – 18mm MDF to be cut on site as required.	18mm thick	Others	4
	<b>Decorative Tape</b> – Sika Closed Cell tape for applying to centre of timber or steel studs or battens at panel joints to give the expressed joint an attractive black finish.	26mm x 1.6mm x 23m 1 x roll	132317	1,2,3,4,5
	<b>Double sided Adhesive Tape</b> – SikaTack Panel Fixing Tape for holding panel in place while adhesive sets.	12mm x 3.3mm x 33m 1 x roll	140681	1,2,3,4
	<b>Panel Adhesive</b> – SikaTack Panel-10 adhesive. Used to adhere panels to timber or steel studs or timber/MDF battens.	600ml 1 x sausage	154403	1,2,3,4

## 05





## COMPONENTS + ACCESSORIES

Note: Codes can change from time to time. Refer to the website for the current list of components prior to ordering.

\* **Fixing System Options** 1 = direct adhesive to timber stud 2 = direct adhesive to steel stud 3 = timber battens (retrofit)  
4 = split timber/MDF battens 5 = rivet to steel stud

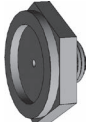

Other Accessories	Description	Size	Product Code	Fixing System Option*
	<b>Primer</b> – Sika Primer 215. Applied to timber stud or timber/MDF batten surfaces prior to application of the SikaTack panel tape and adhesive.	250ml	140550	1,3,4
	<b>Aktivator</b> – Sika Aktivator 100. Applied to steel studs prior to the application of the primer.	1ltr	140611	2
	<b>Primer</b> – Sika Primer 206 G+P. Applied to the steel stud over the Sika Aktivator 100 and before SikaTack panel tape and adhesive. Also used to prime the back of the panels.	250ml 1ltr	140549 167974	1,2,3,4
	<b>Horizontal Backing Strip</b> – used for backing horizontal sheet joints. High tensile Colorbond steel. Black.	1194mm 2394mm 2994mm	21089 21088 21087	1,2,5

**Tools – Cemintel requires Surround rivets to be fixed with the following rivet tools to ensure a high level of accuracy.**

	<b>Surround Drill Bit Ø 9.5mm</b> – for drilling accurate holes in the Surround panel to accept the Surround rivet. Fits standard 10mm drill chuck.	1 each	132673
	<b>Surround Rivet Centralising Tool</b> – for drilling accurate rivet holes in the top hats. Fits a 10mm drill chuck to ensure that the 4.1mm rivet hole is perfectly centred in the pre-drilled panel.	1 each	132674
	<b>Surround Drill Bit Ø 4.1mm</b> – for use with Rivet Centralising Tool to drill accurate rivet holes into the Top Hats.	1 each (pack of 5)	132675
	<b>Surround Blind Rivet Gun</b> – Cemintel recommends the use of the GESIPA® Accubird Battery Operated Blind Rivet Gun.	1 each	47082
	<b>Surround Rivet Gun Nose Piece</b> – required to achieve the correct rivet fixing and offset. Attaches to the Gesipa Accubird battery operated, blind rivet gun and ensures the correct spacing of the rivet head from the panel face. Also designed to seat the larger rivet head correctly and prevent damage to the coloured rivet head. Note: Standard rivet gun nose piece is NOT ACCEPTABLE.	1 each	132676

### Other Tools

CSR recommends the use of the following tools in conjunction with appropriate dust reduction methods

Product	Description	Size	Quantity	Product Code
	<b>Makita Plunge Saw Kit (1300W) includes 1400mm guide rail and bonus 165mm fibre cement saw blade</b> – excellent for cutting cement based sheets	165mm	1	165485
	<b>Makita 165mm Fibre Cement Saw Blade</b> – ideal for use with the Makita Plunge saw and other 165mm circular saws fitted with vacuum extraction systems	165mmx20x4T	1	165486
	<b>Makita VC3012M Dust Extraction Vacuum</b>		Supplied by others	



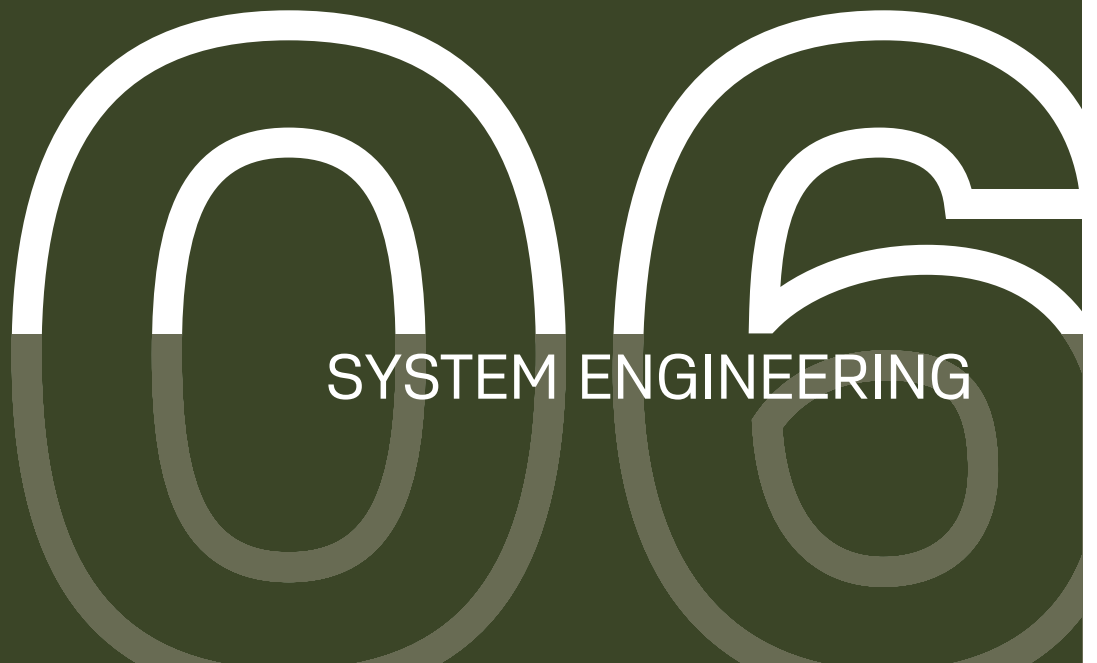

0066

SYSTEM ENGINEERING



## SYSTEM ENGINEERING

---

### Design, Detailing And Performance Responsibilities

Cemintel does not provide consulting services. Cemintel only provides information that has been prepared by others and therefore shall not be considered experts in the field.

Any party using the information contained in this guide or supplied by Cemintel in the course of a project must satisfy themselves that it is true, current and appropriate for the application, consequently accepting responsibility for its use.

It is the responsibility of the architectural designer and engineering parties to ensure that the details in this design guide are appropriate for the intended application.

The recommendations in this guide are formulated along the lines of good building practice, but are not intended to be an exhaustive statement of all relevant data.

Cemintel is not responsible for the performance of constructed walls, including field performance and does not interpret or make judgements about performance requirements in the NCC.

#### **Wind Loads**

All support framing must be designed for the applicable wind pressures.

Concealed fix systems using Sika adhesives and rivet fix systems are suitable for interior design pressure up to 1.0kPa.

CSR recommends installation of structural steel and timber framing in accordance with the manufacturer and designer instructions.

# 07

INSTALLATION

**FIXING OPTION 1****CONCEALED FIXING – ADHESIVE TO TIMBER STUD**

The following pre-install checklist may assist with ensuring you have the best possible outcome when using Surround.



Check quality and quantity of panels and components before installing. If there is any sign of damage or visible defects in panels, or the colour/finish is not in keeping with the owners aesthetic requirements DO NOT INSTALL. Contact Cemintel to address any issues.

- Confirm framing alignment is in accordance with AS 1684 Residential Timber-Framed Construction. Pack to straighten if necessary. Check with certifier regarding packing materials.
- Confirm your panel layout to determine the location of joints. Ensure studs are correctly located and of the appropriated thickness. Install additional studs if required (double studs are required at all vertical sheet joints).
- Ensure **studs** have been appropriately treated with primers (refer to following for details).
- Ensure **panels** have been appropriately treated (refer to following for details).
- Confirm the use of the backing strip if required.
- Check the panel size and trim cut if required to maintain the correct expressed joint size.

**FIGURE 7.01** Concealed fixing on timber frame

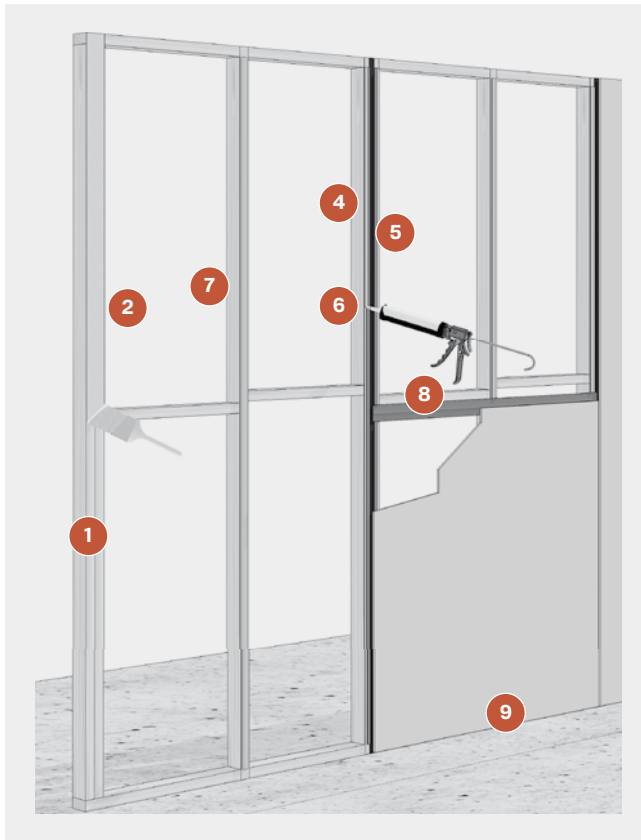

## FIXING OPTION 1

- 1 **Ensure that studs are at correct centres** and that there are double studs at all vertical joints. Ensure the face of the frame is aligned.
- 2 **Treatment of timber studs**
  - Dry wipe stud faces.
  - Apply a thin coat of Sika Primer 215 to the entire stud face using a dry, clean brush or sponge.
  - Let dry for at least 30mins (>15°C) / 60mins (<15°C) or maximum 24hrs (follow manufacturer's instructions).

Note that Aktivators should NOT be used on porous substrates such as timber.

- 3 **Prepare Surround panels**
  - Abrade/scuff bonding area (ie the areas on the back of the panel that will coincide with the timber studs) with a polyester scouring pad (i.e. 3M Scotch Brite Pad 7447).
  - Remove dust from abrasion.
  - Shake can of Sika Primer 206 G&P thoroughly and apply a thin coat with a brush on the bond area as shown in 'Figure 7.02: Surround Panel Preparation'.

**Note:** Do not dip brush directly into the bottle as this may introduce contaminants. Rather, decant the contents into a suitable clean container. Close the bottle immediately after use.

  - Allow Sika Primer 206 G&P to dry for a minimum of 10 minutes, or maximum 24 hours.
- 4 **Apply the Sika decorative closed cell tape** centrally onto the primed vertical joints at double studs to the full height of the wall.

- 5 **Apply SikaTack double sided panel tape to the double stud on both sides of the closed cell tape.** Leave the release paper on the SikaTack panel tape and stop short at the top and bottom plates. Refer to 'Figure 7.03: Closed Cell Tape, Adhesive, Tape Layout'. And 'Figure 7.04: Sheet Joint Layout'.

FIGURE 7.02 Surround Panel Preparation

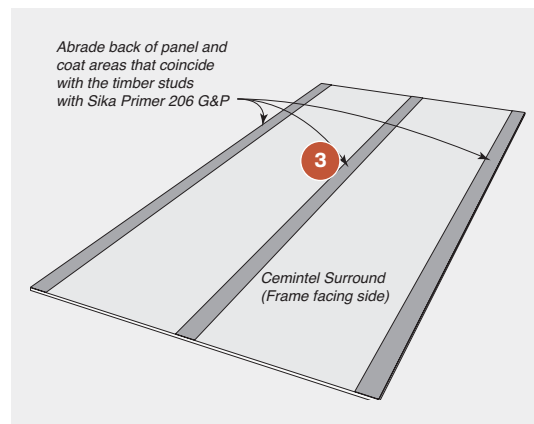

FIGURE 7.03 Closed Cell Tape, Adhesive, Tape Layout

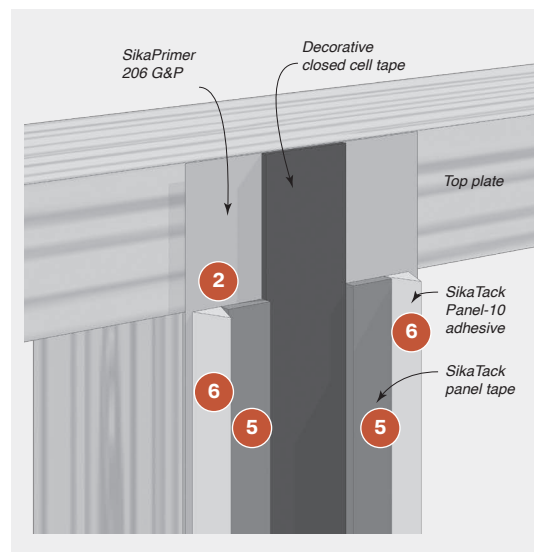
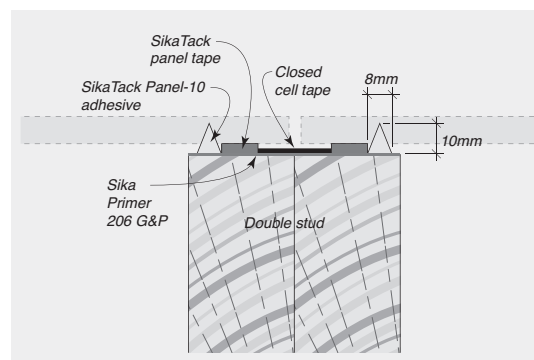
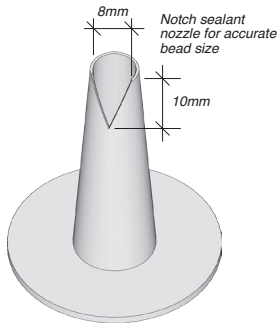

FIGURE 7.04 Sheet Joint Layout



## FIXING OPTION 1



- 6 Cut a “v” on the SikaTack Panel-10 adhesive\* cartridge nozzle** of 8mm wide x10mm deep. Continuously run two triangular beads (8mm wide, 10mm deep) of SikaTack Panel-10 adhesive vertically to the bond area on the timber studs either side of the SikaTack panel tape but stop short at the top and bottom plates. \*Note: the open time (or working time) of SikaTack Panel-10 is 45 minutes (at normal conditions of 23 degrees Celsius, 50% relative humidity), so the panel must be pressed onto the adhesive/tape system within that time or less.
- 7 At intermediate studs.** Run SikaTack panel tape and one bead of SikaTack Panel-10 adhesive the full height of the stud but stop short at the top and bottom plates. Refer to 'Figure 7.05: Intermediate Stud Layout'.
- 8 Install horizontal backing strip** by removing release paper on the SikaTack panel tape and pressing onto the tape and adhesive, as shown in 'Figure 7.06: Horizontal Backing Strip'.
- 9 When panels are ready to be installed,** remove white release paper on the SikaTack panel fixing tape and firmly press the panel onto the tape and adhesive. The tape will provide adequate hold strength while the adhesive sets.

Allow 6mm clearance between bottom panel and floor to allow for frame movement/shrinkage.

**Tip:** Use packers (or cut panels) at the base vertical and horizontal joints to ensure uniform joint spacings. Remove once the adhesive is set. Refer to 'Figure 7.07: Panel Installation'.

FIGURE 7.05 Intermediate Stud Layout

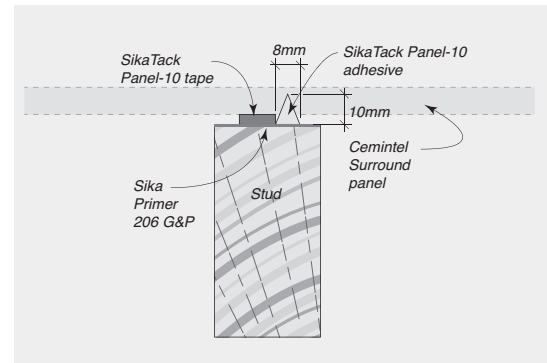

FIGURE 7.06 Horizontal Backing Strip

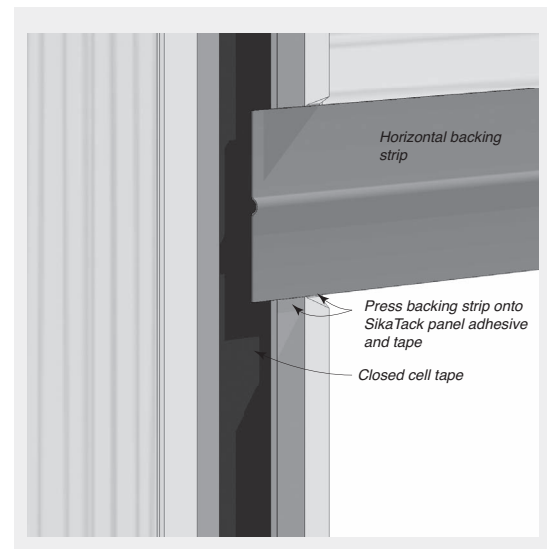
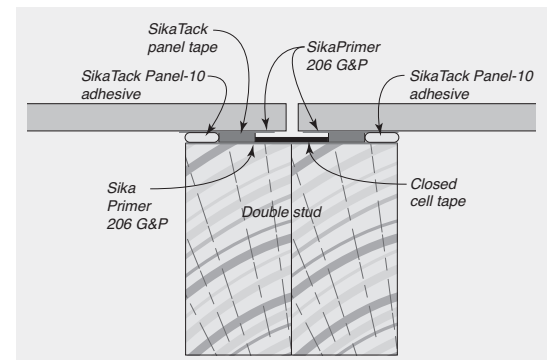

FIGURE 7.07 Panel Installation



**FIXING OPTION 2****CONCEALED FIXING – ADHESIVE TO STEEL STUD**

The following pre-install checklist may assist with ensuring you have the best possible outcome when using Surround.

- Confirm framing alignment is in accordance with AS/NZS 4600 Cold-Formed Steel Structures and AS 3623 Domestic Metal Framing). Pack to straighten if necessary. Check with certifier regarding packing materials.
- Confirm your panel layout to determine the location of joints. Ensure studs are correctly located and of the appropriated thickness. Install additional studs if required (double studs are required at all vertical sheet joints).
- Ensure **studs** have been appropriately treated with primers (refer to following for details).
- Ensure **panels** have been appropriately treated (refer to following for details).
- Confirm the use of the backing strip if required.
- Check the panel size and trim cut if required to maintain the correct expressed joint size.



Check quality and quantity of panels and components before installing. If there is any sign of damage or visible defects in panels, or the colour/finish is not in keeping with the owners aesthetic requirements **DO NOT INSTALL**. Contact Cemintel to address any issues.

**FIGURE 7.08** Concealed Fixing on Steel Frame

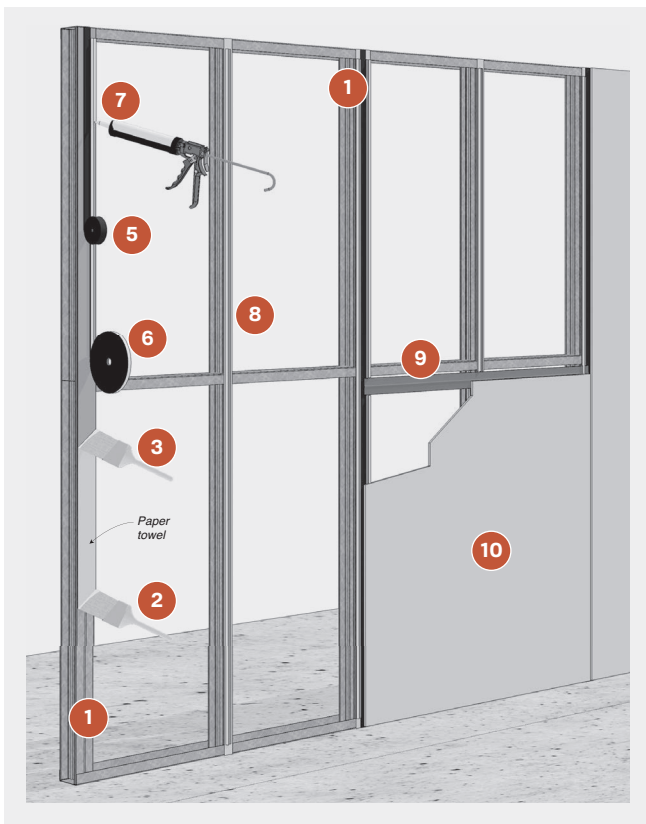

## FIXING OPTION 2

- 1 **Ensure that studs are at correct centres** and that there are double studs at all vertical joints. Ensure the face of the frame is aligned.
- 2 **Treatment of steel studs (Aktivator)**
  - Abrade bonding area with a polyester scouring pad (i.e. 3M Scotch Brite Pad 7447).
  - Remove dust from abrasion.
  - Apply Sika Aktivator-100 on stud face / bond area with a clean lint free paper towel. Turn and change the towel frequently. Immediately remove excess with a dry, clean paper towel (wipe on/ wipe off).
  - Allow Sika Aktivator-100 to dry for at least 10 minutes (>15°C) / 30 minutes (<15°C) or maximum 2 hours (follow manufacturer's instructions). Close bottle immediately after use.
- 3 **Treatment of steel studs (Primer)**
  - Shake can of Sika Primer 206 G&P thoroughly and apply a thin coat with a clean dry brush or sponge.
  - Allow Sika Primer 206 G&P to dry for a minimum of 10 minutes (>15°C) / 30 minutes (<15°C) or a maximum 24 hours (follow manufacturer's instructions).

## 4 Prepare Surround panels

- Abrade bonding area (ie the areas on the back of the panel that will coincide with the steel stud/ furring channel) with a polyester scouring pad (i.e. 3M Scotch Brite Pad 7447).
- Remove dust from abrasion.
- Shake can of Sika Primer 206 G&P thoroughly and apply a thin coat with a brush on the bond area as shown in 'Figure 7.09: Surround Panel Preparation'. Note - Do not dip brush directly into the bottle as this may introduce contaminants. Rather, decant the contents into a suitable clean container. Close the bottle immediately after use.
- Allow Sika Primer 206 G&P to dry for a minimum of 10 minutes, or maximum 24 hours.

**FIGURE 7.09** Surround Panel Preparation

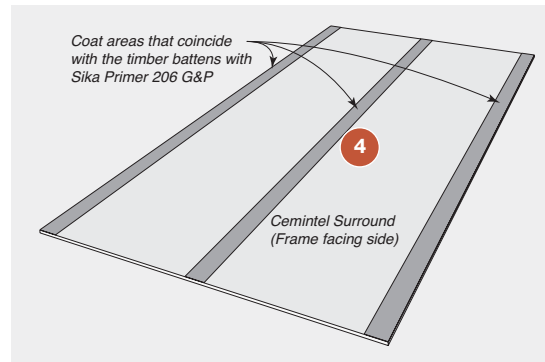

- 5 **Apply the Sika decorative closed cell tape** centrally onto the primed vertical joints at double studs to the full height of the wall.



**FIXING OPTION 2****CONCEALED FIXING – ADHESIVE TO STEEL STUD**

- 6** Apply SikaTack double sided panel tape to the double stud on both sides of the closed cell tape. Leave the release paper on the SikaTack panel tape and stop short at the top and bottom plates. Refer to 'Figure 7.10: Closed Cell tape, adhesive, Tape Layout' and 'Figure 7.11: Sheet Joint Layout'.
- 7** Cut a "v" on the SikaTack Panel-10 adhesive\* cartridge nozzle of 8mm wide x10mm deep. Continuously run two triangular beads (8mm wide, 10mm deep) of SikaTack Panel-10 adhesive vertically to the bond area on the steel studs either side of the SikaTack panel tape but stop short at the top and bottom plates.
- \*Note:** The open time (or working time) of SikaTack Panel-10 is 45 minutes (at normal conditions of 23 degrees Celsius, 50% relative humidity), so the panel must be pressed onto the adhesive/tape system within that time or less.

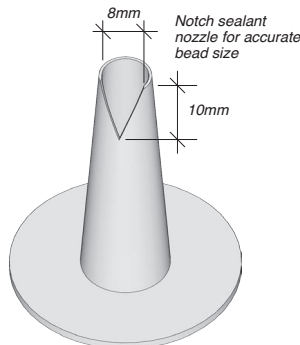

- 8** At intermediate studs Run SikaTack panel tape and one bead of SikaTack Panel-10 adhesive the full height of the stud but stop short at the top and bottom plates. Refer to 'Figure 7.12: Intermediate Stud Layout'.

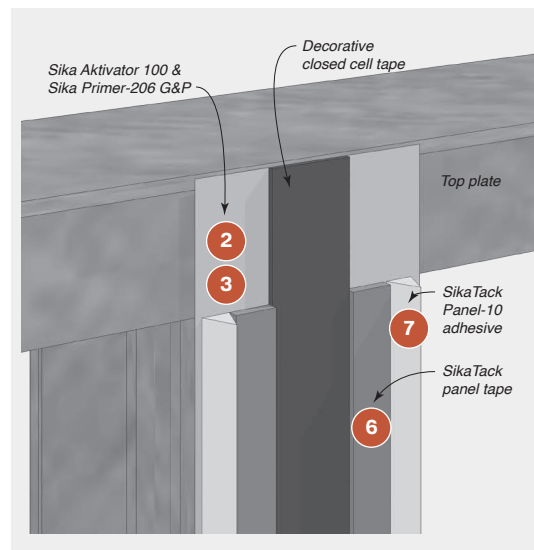
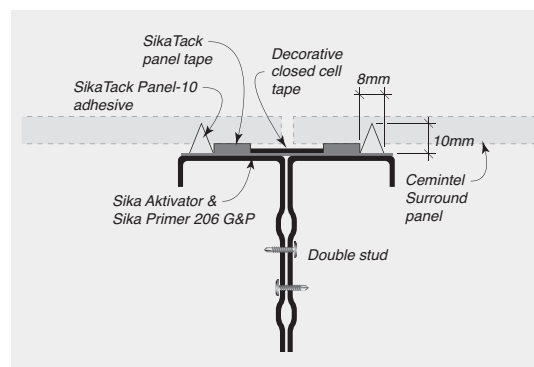
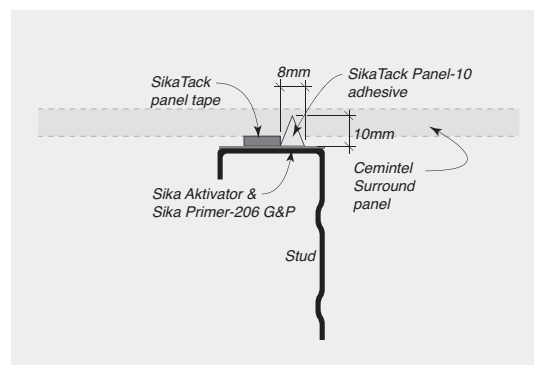
**FIGURE 7.10** Closed Cell Tape, Adhesive Layout**FIGURE 7.11** Sheet Joint Layout**FIGURE 7.12** Intermediate Stud Layout

## FIXING OPTION 2

- 9 **Install horizontal backing strip** by removing release paper on the SikaTack panel tape and pressing onto the tape and adhesive, as shown in 'Figure 7.13: Horizontal Backing Strip'.
- 10 When panels are ready to be installed, remove white release paper on the SikaTack panel Fixing tape and firmly press the panel onto the tape and adhesive. The tape will provide adequate hold strength while the adhesive sets.

Allow 5-6mm clearance between bottom panel and floor to allow for frame movement.

**Tip:** Use packers (or cut panels) at base (vertical) and horizontal joints to ensure uniform joint spacings. Remove once the adhesive is set. Refer to 'Figure 7.14: Panel Installation'.

**FIGURE 7.13** Horizontal Backing Strip

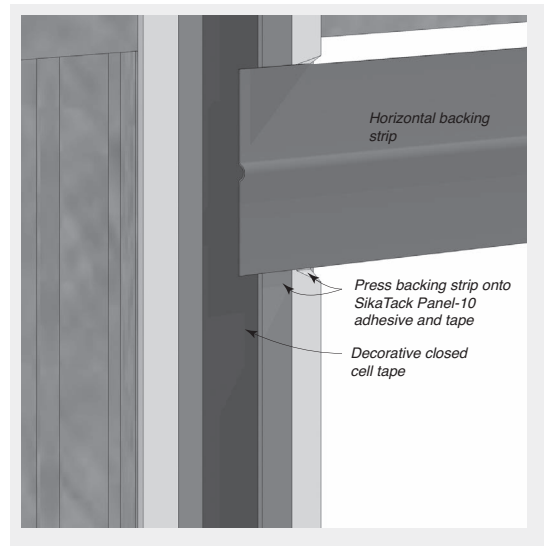

**FIGURE 7.14** Panel Installation

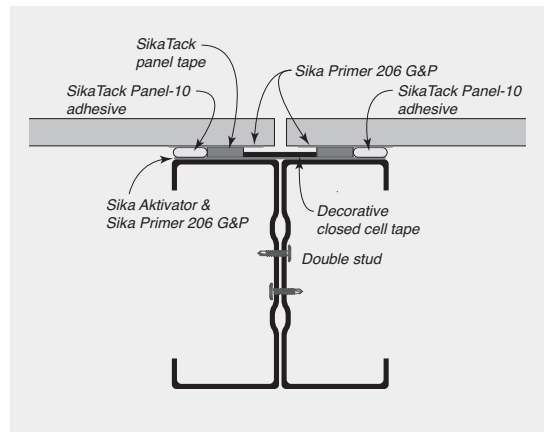

**FIXING OPTION 3****CONCEALED FIXING – TIMBER BATTENS FOR RETROFIT OVER EXISTING LININGS**

The following pre-install checklist may assist with ensuring you have the best possible outcome when using Surround.

- Confirm framing alignment is in accordance with standards (timber frames as per AS 1684, steel frames as per AS/NZS 4600 Cold-Formed Steel Structures and AS 3623 Domestic Metal Framing). Pack to straighten if necessary. Check with certifier regarding packing materials.
- Confirm your panel layout to determine the location of joints. Ensure studs are correctly located and of the appropriated thickness. Install additional studs if required (double studs are required at all vertical sheet joints).
- Install vertical and horizontal battens where required.
- Ensure **studs** have been appropriately treated with primers (refer below for details).
- Ensure **timber battens** have been appropriately treated with primers (refer to following for details).
- Ensure **panels** have been appropriately treated (refer to following for details).
- Check the panel size and trim if required to maintain the correct expressed joint size.
- Confirm correct placement of closed cell tape gaskets, SikaTack panel and tape and adhesive.
- When installing the panel ensure the panel is firmly pressed against the tape and that good contact is made.
- Use packers to ensure even joint spacings, remove once adhesive is set.



Check quality and quantity of panels and components before installing. If there is any sign of damage or visible defects in panels, or the colour/finish is not in keeping with the owners aesthetic requirements **DO NOT INSTALL**. Contact Cemintel to address any issues.

**FIGURE 7.15** Concealed fixing on Timber Frame



### FIXING OPTION 3

- 1 **Locate existing studs and mark batten locations.** Ensure that the face of the wall is aligned. Note that due to the addition of an expressed joint, misalignment can occur between panel joints and batten placement. Sheet trimming may be required to maintain uniform joint spacing and to ensure battens remain on studs.
- 2 **Install timber battens at head and base of wall**  
Install 66mmx18mm timber battens horizontally across the top and bottom of the wall. Fix with screws, nails or adhesive.
- 3 **Install timber battens vertically.** Install 92mmx18mm timber battens at all vertical joint locations. Install 66mmx18mm timber battens at intermediate stud locations. Fix at 300mm centres. Vertical battens may be installed slightly off stud centre but batten fixing must be driven into the stud (ie the edge of the batten must still be on the stud). In some case this may help when allowing for an express joint. Refer to 'Figure 7.16: Batten Fixing to Existing Stud'. Nail or screw fix at 400mm maximum centres.

FIGURE 7.16 Batten Fixing to Existing Stud

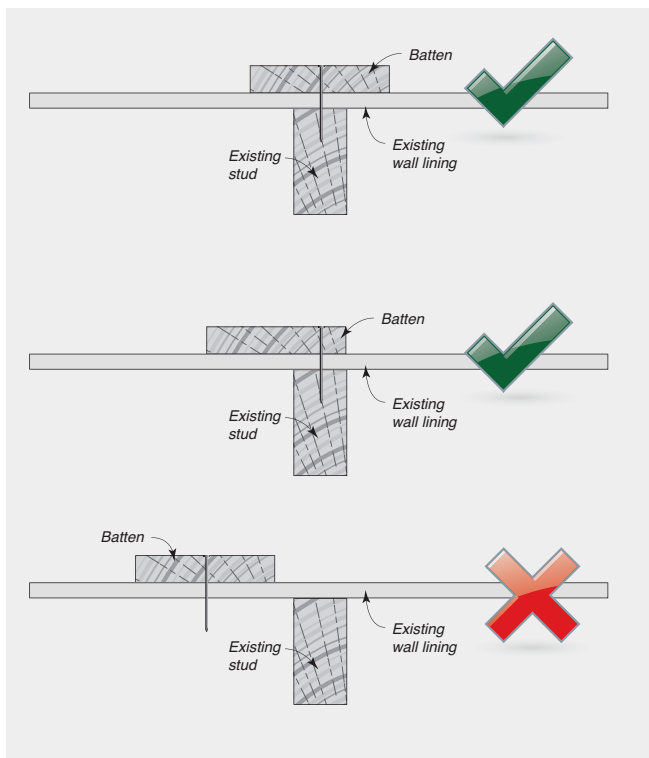

- 4 **Install timber battens horizontally.** Install 66mmx18mm timber battens at all horizontal joint locations. Fix at 300mm centres with screws, nails or adhesive. Refer to 'Figure 7.17: Horizontal Panel Joint'.

FIGURE 7.17 Horizontal Panel Joint

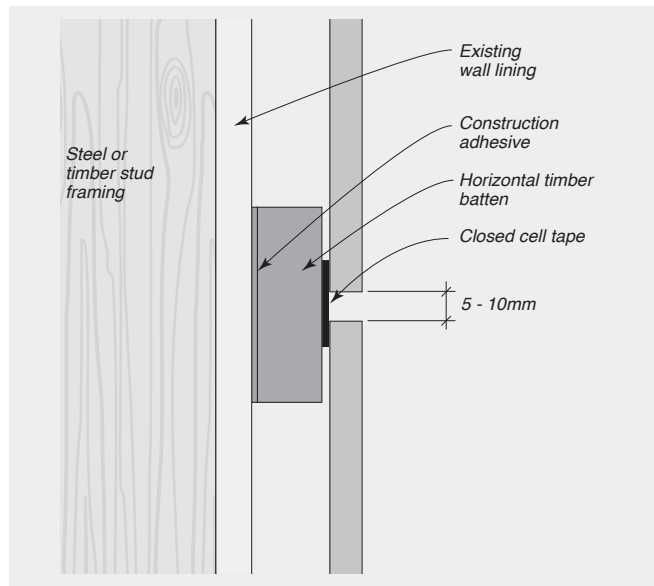

### 5 Treatment of timber battens

- Dry wipe timber batten faces.
- Apply a thin coat of Sika Primer 215 to the entire stud face using a dry, clean brush or sponge.
- Let dry for at least 30mins (>15°C) / 60mins (<15°C) or maximum 24hrs (follow manufacturer's instructions).

Note that Aktivators should NOT be used on porous substrates such as timber.

### 6 Prepare Surround panels

- Abrade bonding area (ie the areas on the back of the panel that will coincide with the timber studs) with a polyester scouring pad (i.e. 3M Scotch Brite Pad 7447).
- Remove dust from abrasion.
- Shake can of Sika Primer 206 G&P thoroughly and apply a thin coat with a brush on the bond area as shown in 'Figure 7.18: Surround Panel Preparation'.

**Note:** Do not dip brush directly into the bottle as this may introduce contaminants. Rather, decant the contents into a suitable clean container. Close the bottle immediately after use.

Allow Sika Primer 206 G&P to dry for a minimum of 10 minutes, or maximum 24 hours

### FIXING OPTION 3

- 7 **Apply the Sika decorative closed cell tape** centrally onto the primed battens where panel joints occur, for the full length of the battens.
- 8 **Apply SikaTack double sided panel tape to the vertical battens where panel joints occur on both sides of the closed cell tape.** Leave the release paper on the SikaTack panel tape and stop short at the top and bottom plates. Refer to 'Figure 7.19: Vertical Panel Joint Layout'.
- 9 **Cut a "v" on the SikaTack Panel-10 adhesive\* cartridge nozzle** of 8mm wide x 10mm deep. Continuously run two triangular beads (8mm wide, 10mm deep) of SikaTack Panel-10 adhesive vertically to the bond area on the timber battens either side of the SikaTack panel tape but stop short at the top and bottom plates. \*Note: the open time (or working time) of SikaTack Panel-10 is 45 minutes (at normal conditions of 23 degrees Celsius, 50% relative humidity), so the panel must be pressed onto the adhesive/tape system within that time or less.

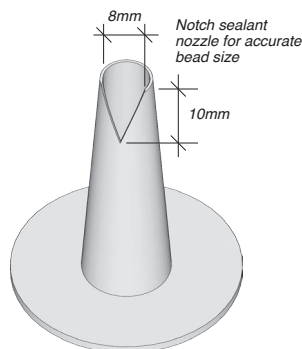

- 10 **At intermediate studs.** Run SikaTack panel tape and one bead of SikaTack Panel-10 adhesive the full height of the batten but stop short at the horizontal closed cell tape. Refer to 'Figure 7.20: Intermediate Batten Layout'.
- 11 **When panels are ready to be installed,** remove white release paper on the SikaTack panel tape and firmly press the panel onto the tape and adhesive. The tape will provide adequate hold strength while the adhesive sets.

When using steel frames, at deflection heads, do not fix Surround to deflection head track. Refer to 'Figure 7.21: Panel Installation'.

**Tip:** Use packers (or cut panels) at base and horizontal joints to ensure uniform joint spacings. Remove once the adhesive is set.

FIGURE 7.18 Surround Panel Preparation

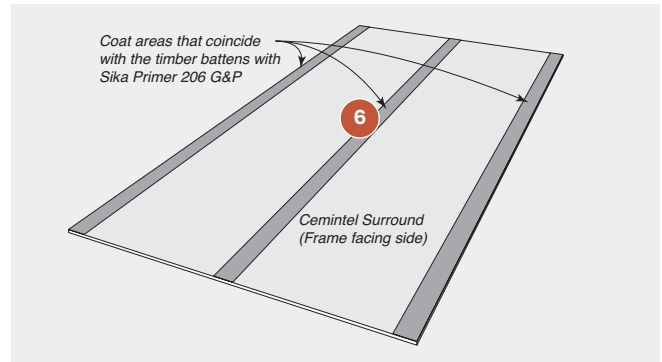

FIGURE 7.19 Vertical Panel Joint Layout

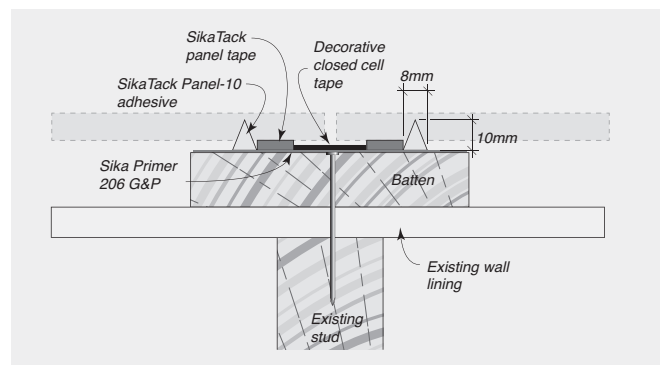

FIGURE 7.20 Intermediate Batten Layout

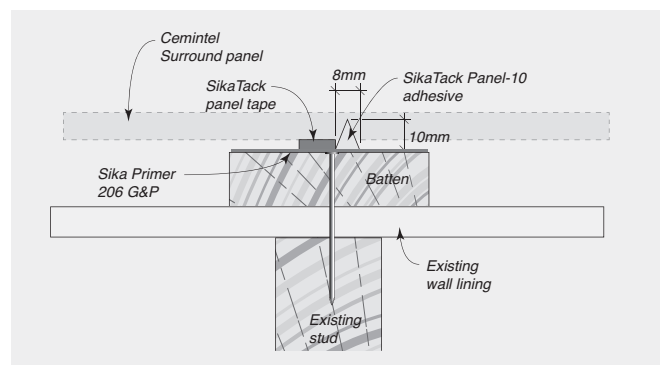
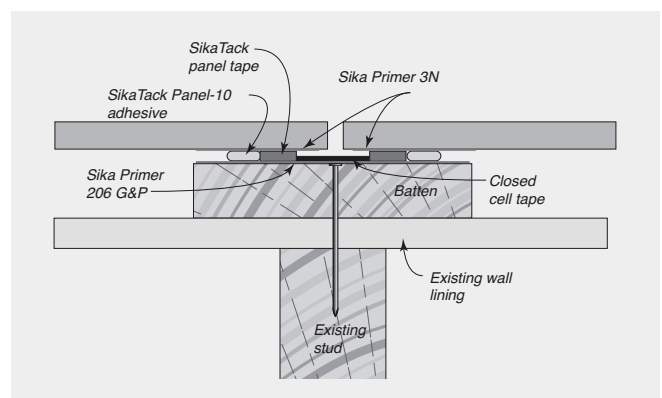

FIGURE 7.21 Panel Installation



**FIXING OPTION 4****CONCEALED FIXING - TIMBER/MDF SPLIT BATTENS**

The following pre-install checklist may assist with ensuring you have the best possible outcome when using Surround.



Check quality and quantity of panels and components before installing. If there is any sign of damage or visible defects in panels, or the colour/finish is not in keeping with the owners aesthetic requirements DO NOT INSTALL. Contact Cemintel to address any issues.

- Confirm framing alignment is in accordance with standards (timber frames as per AS 1684, steel frames as per AS/NZS 4600 Cold-Formed Steel Structures and AS 3623 Domestic Metal Framing). Pack to straighten if necessary. Check with certifier regarding packing materials.
- Confirm your panel layout to determine the location of joints. Ensure studs are correctly located and of the appropriated thickness. Install additional studs if required (double studs are required at all vertical sheet joints).
- Install vertical and horizontal MDF strips where required.
- Ensure **horizontal timber/MDF battens** have been appropriately treated with primers (refer to following for details).
- Ensure **panels** have been appropriately treated (refer to following for details).
- Check the panel size and trim if required to maintain the correct expressed joint size.
- Confirm correct placement of decorative closed cell tape and SikaTack Panel-10 adhesive.
- When installing the panel ensure the panel is firmly pressed against the tape and that good contact is made.
- Use packers to ensure even joint spacings, remove once adhesive is set.

**FIGURE 7.22** Concealed Fixing on Steel Frame



## INSTALLATION

07

## FIXING OPTION 4

- 1 **Ensure that studs are at correct centres** and that there are double studs at all vertical joints. Mark batten locations. Ensure that the face of the wall is aligned.
- 2 **Install MDF strips vertically.** Cut minimum 25mm wide batten strips from an MDF sheet and install centrally at all double studs for the full height of the wall.

For timber framing, brad nail at 600mm centres staggered, with an edge distance of 5mm. Where screw fixing, pre-drill MDF strips at 5mm edge distance vertical centres staggered. For steel framing screw fix at 600mm. Refer to 'Figure 7.27 Panel Installation – Vertical Joint'.

- 3 **Install MDF strips horizontally.** Cut minimum 25mm wide strips of MDF sheet and install at horizontal joints for the full joint width, and at the head and base.

Fasten at each stud. Brad nail for timber framing, pre-drill and screw fix for steel frame.

- 4 **Apply the Sika decorative closed cell tape** centrally onto the MDF batten strips, horizontally and vertically the full length of the strips.
- 5 **Make split battens.** Cut a 140mm wide MDF plank in half down the centre at 45°. Refer to 'Figure 7.23: Split Batten Preparation'.
- 6 **Fix split battens.** Fix the lower half of the split batten horizontally onto the steel frame with 2 screws and the timber frame with 1 screw, per connection. Place the upper batten half into position on the lower half. Battens are to be 100mm in from sheet ends, and at 600mm maximum spacing for 2 split batten supports (single span) and 800mm maximum spacings for 3 or more split batten supports (multiple spans). Refer to 'Figure 7.24: Split Batten Assembly'.
- 7 **Treatment of split battens.**
  - Dry wipe split batten faces.
  - Apply a thin coat of Sika Primer 215 to the top half of the split batten using a dry, clean brush or sponge.
  - Let dry for at least 30mins (>15°C) / 60mins (<15°C) or maximum 24hrs (follow manufacturer's instructions).

**Note:** That Aktivators should NOT be used on porous substrates such as timber.

- 8 **Prepare Surround panels**

- Abrade bonding area (ie the areas on the back of the panel that will coincide with the top half of the split batten) with a polyester scouring pad (i.e. 3M Scotch Brite Pad 7447)
- Remove dust from abrasion
- Shake can of Sika Primer 206 G&P thoroughly and apply a thin coat with a brush on the bond area as shown in figure 7.25: Surround Panel Preparation and 'Figure 7.24: Split Batten Assembly'.

**Note:** Do not dip brush directly into the bottle as this may introduce contaminants. Rather, decant the contents into a suitable clean container. Close the bottle immediately after use. Allow Sika Primer 206 G&P to dry for a minimum of 10 minutes, or maximum 24 hours.

FIGURE 7.23 Split Batten Preparation

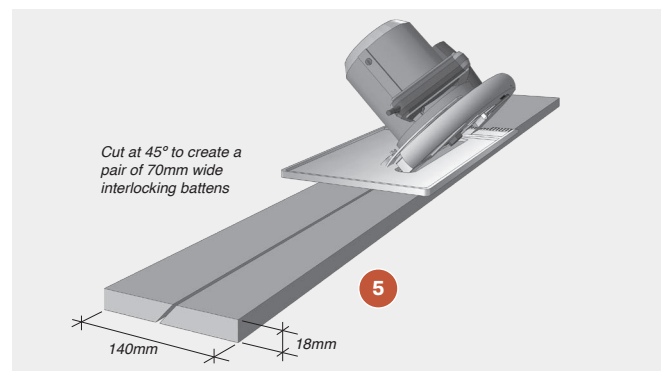

FIGURE 7.24 Split Batten Assembly

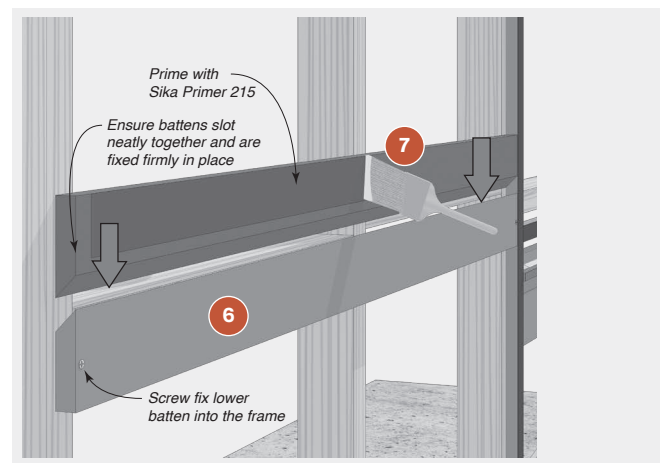
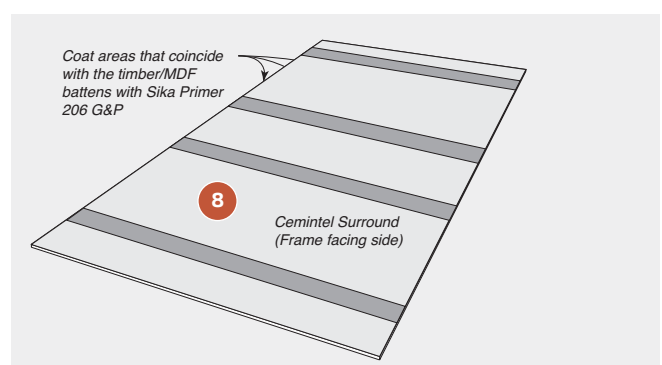

FIGURE 7.25 Surround Panel Preparation



## FIXING OPTION 4

- 9 Apply SikaTack double sided panel tape to the top half of the split batten. Leave the release paper on the SikaTack panel tape. Cut a “v” on the SikaTack Panel-10 adhesive\* cartridge nozzle of 8mm wide x 10mm deep. Run a triangular bead (8mm wide, 10mm deep) of SikaTack Panel-10 adhesive to the bond area on the MDF battens above the SikaTack panel tape but stop 20mm short of the batten ends. Refer to ‘Figure 7.26: Adhesive and Tape on Split Batten’.

**\*Note:** The open time (or working time) of SikaTack Panel-10 adhesive is 45 minutes (at normal conditions of 23 degrees Celsius, 50% relative humidity), so the panel must be pressed onto the adhesive/tape system within that time or less.

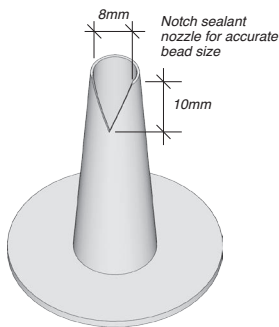
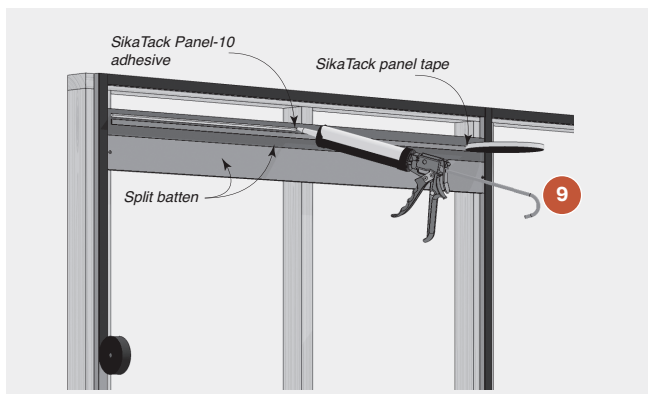

FIGURE 7.26 Adhesive and Tape on Split Batten



- 10 When panels are ready to be installed, remove white release paper on the SikaTack panel tape and firmly press the panel onto the tape and adhesive. The tape will provide adequate hold strength while the adhesive sets.

**Tip:** Use packers (or cut panels) at base (vertical) and horizontal joints to ensure uniform joint spacings. Remove once the adhesive is set.

**Note:** An 18mm minimum expressed joint gap is required at the top of the panels to allow the split battens to be “unhooked” and the panel removed.

FIGURE 7.27 Panel Installation – Vertical Joint

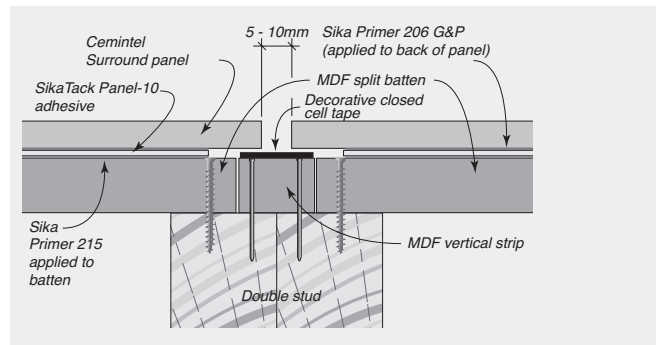
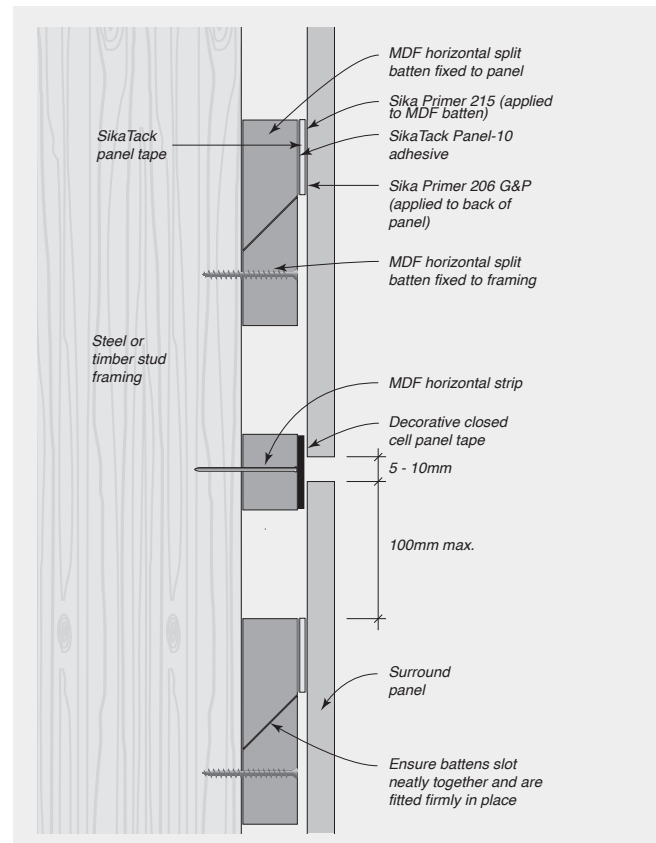

FIGURE 7.28 Concealed Horizontal Split Battens





**FIXING OPTION 5****EXPOSED FIXING – RIVET TO STEEL FRAMING**

The following pre-install checklist may assist with ensuring you have the best possible outcome when using Surround.

- Confirm framing alignment is in accordance with AS/NZS 4600 Cold-Formed Steel Structures and AS 3623 Domestic Metal Framing. Pack to straighten if necessary. Check with certifier regarding packing materials.
- Confirm your panel layout to determine the location of joints. Ensure studs are correctly located and of the appropriated thickness. Install additional studs if required (double studs are required at all vertical sheet joints).
- Confirm the use of the backing strip if required.
- Check the panel size and trim cut if required to maintain the correct expressed joint size.



Check quality and quantity of panels and components before installing. If there is any sign of damage or visible defects in panels, or the colour/finish is not in keeping with the owners aesthetic requirements **DO NOT INSTALL**. Contact Cemintel to address any issues.

**FIGURE 7.29** Concealed Fixing on Steel Frame



## FIXING OPTION 5

- 1 **Ensure that studs are at correct centres** and that there are double studs at all vertical joints. Ensure the face of the frame is aligned.
- 2 **Apply the Sika decorative closed cell tape** centrally onto the vertical joints at double studs to the full height of the wall.
- 3 **Cut Surround panels as required.** Cut panels as required. Run a fine sandpaper block over the edge (taking care not to scratch the panel surface).
- 4 **Pre-drill panel holes.** This should be done prior to lifting panels into place and can be done off site. Panel holes need to be drilled a minimum 100mm from the horizontal edge and a minimum of 20mm from the vertical edge (600mm max centres). Use the recommended Surround 9.5mm carbide tipped drill bit with centring tip.

FIGURE 7.30 Pre-drilling Panels

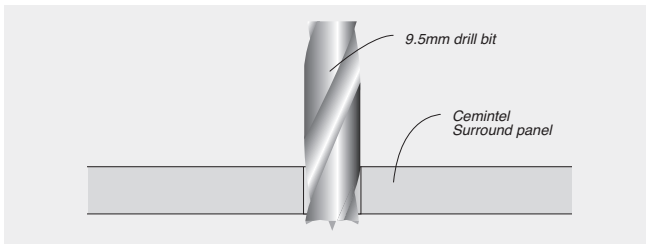

The size of the hole drilled is designed to match the size of the rivet rubber sleeve. The use of other tools for this purpose may reduce fixing capacity.

**DO NOT** use hammering action when drilling.

For efficiency you can neatly stack 3 or 4 sheets and drill through all at the same time. Take care to avoid damaging the panel with the drill chuck when approaching the end of the hole by using a timber block. Clean/sweep away any dust from holes as this can stick to the panel.

FIGURE 7.31 Panel Installation

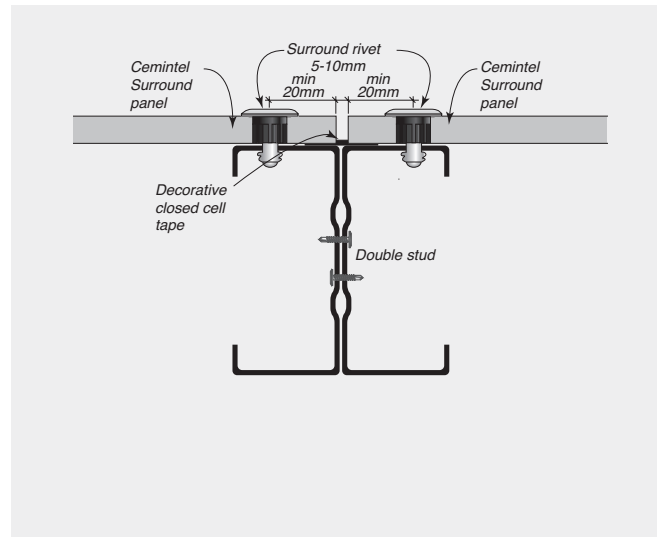

## FIXING OPTION 5

- 5 Install wall panels.** Lift panel into place, clamp down level to identify horizontal and vertical planes. Using the Rivet Centralising Tool, drill 4.1mm rivet holes through the pre drilled panel holes into the top hats. This specialised tool creates a rivet hole, which matches the size of the shaft of the rivet, precisely in the centre of the panel hole (refer Figure 7.32).

**FIGURE 7.32** Centralising Tool

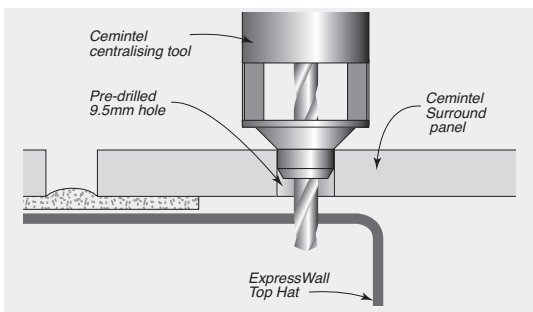

**Fix panel using rivets** – Install Rivet Gun nose piece onto the Gesipa Accubird battery operated blind rivet gun. The nose piece has a slight concave shape which serves to create a small (0.5mm) clearance between the panel face and the rivet flange.

This enables a slight movement across the panel which allows for expansion and contraction cycles and differential movement of the frame while reducing damage to the panel face (refer Figure 7.33).

Fix panel starting at the top corner. Place the rivet gun with the rivet gun head onto the rivet shaft.

Push the panel firmly against the framing/gaskets and operate the gun to pull the rivet through panel hole into the predrilled top hat.

- 6 Install horizontal backing strip if required.**

Slip the backing strip behind the panel before completing the riveting of the panel. Surround panels are generally installed with a nominal 8mm expressed joint in both horizontal and vertical directions (a small cut piece of panel can be used as a spacer to easily measure joint widths and ensure consistency). Once positioned, fasten bottom row of rivets. Refer to 'Figure 7.34: Horizontal Backing Strip Installation'. Tip - Use a small piece of cut panels at vertical and horizontal joints to ensure uniform joint spacings.

**FIGURE 7.33** Fixing with Rivets

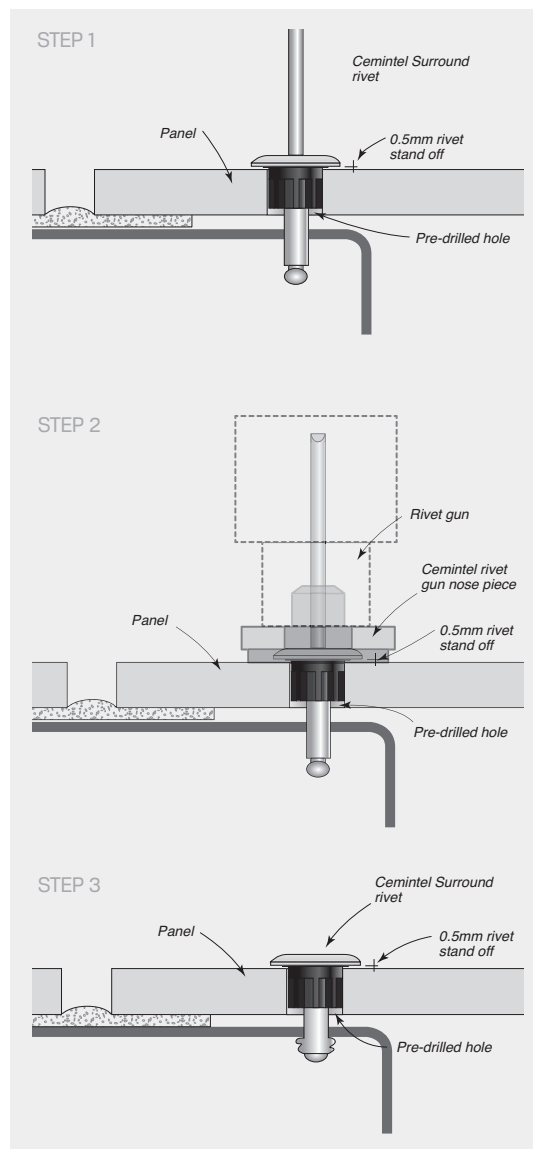

**FIGURE 7.34** Horizontal Backing Strip Installation

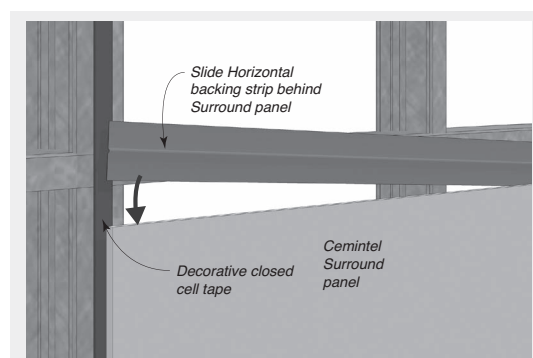



CONSTRUCTION  
DRAWINGS + DETAILS

## CONSTRUCTION DRAWINGS AND DETAILS



Note: Drawings are interchangeable for timber or steel substrates with the exception of the fasteners.

### Drawings Index

SECTION	DESCRIPTION	FIGURE REFERENCE	PAGE NUMBER
<b>Base Details</b>	Base Detail	8.01	38
	Base Detail Alternative	8.02	38
<b>Head Details</b>	Head Detail	8.03	38
	Head Detail Alternative	8.04	38
<b>Corner Details</b>	Obtuse Angle	8.05	39
	External Corner	8.06	39
	Internal Corner	8.07	39



## CONSTRUCTION DRAWINGS AND DETAILS

Note: Drawings are interchangeable for timber or steel substrates with the exception of the fasteners.

**FIGURE 8.01** Base Detail

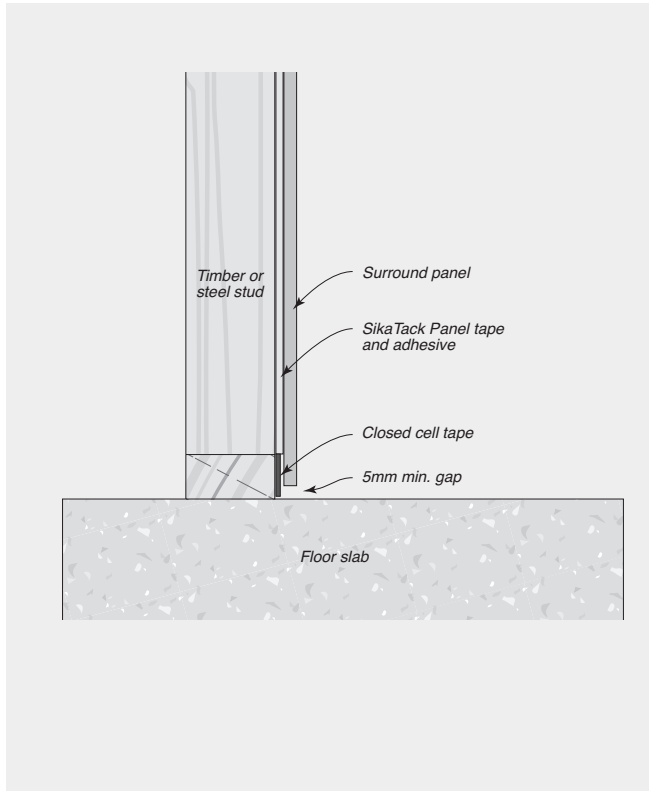

**FIGURE 8.02** Base Detail Alternative

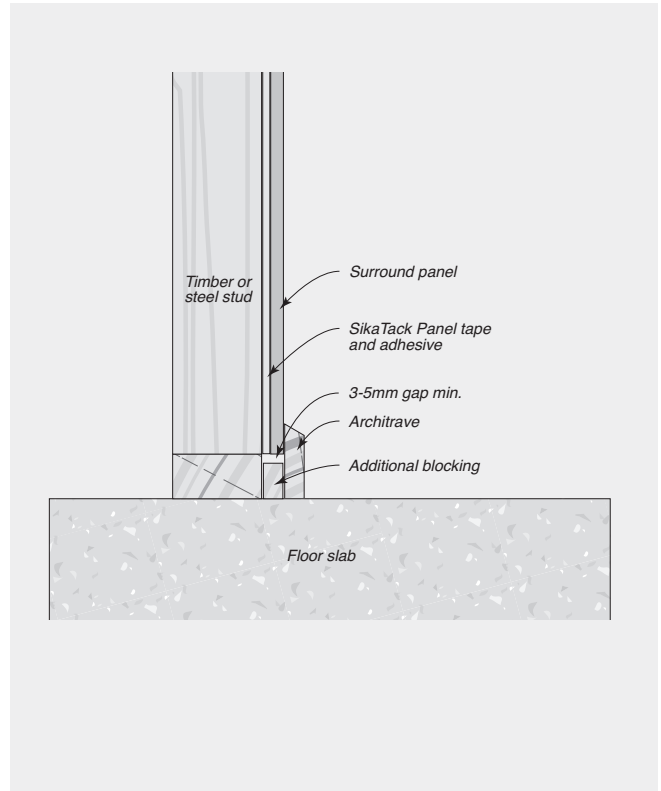

**FIGURE 8.03** Head Detail

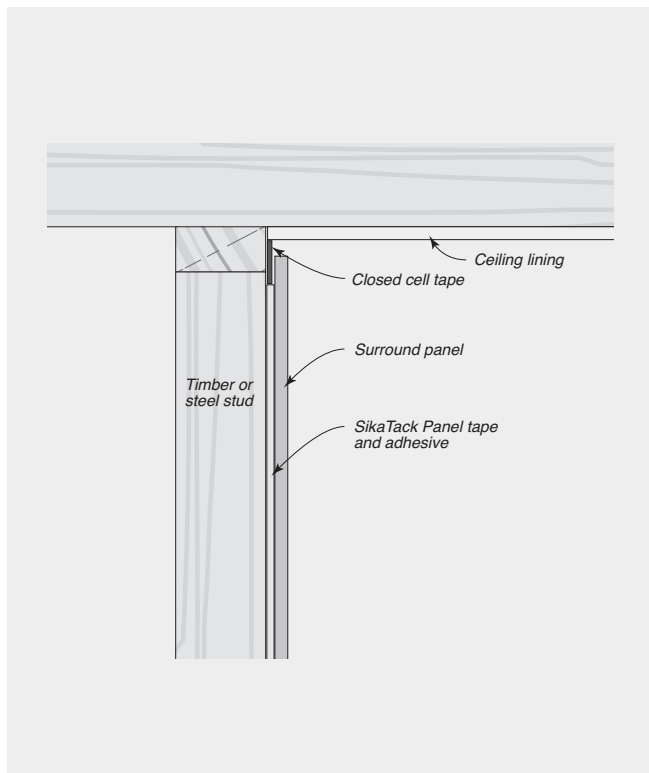

**FIGURE 8.04** Head Detail Alternative

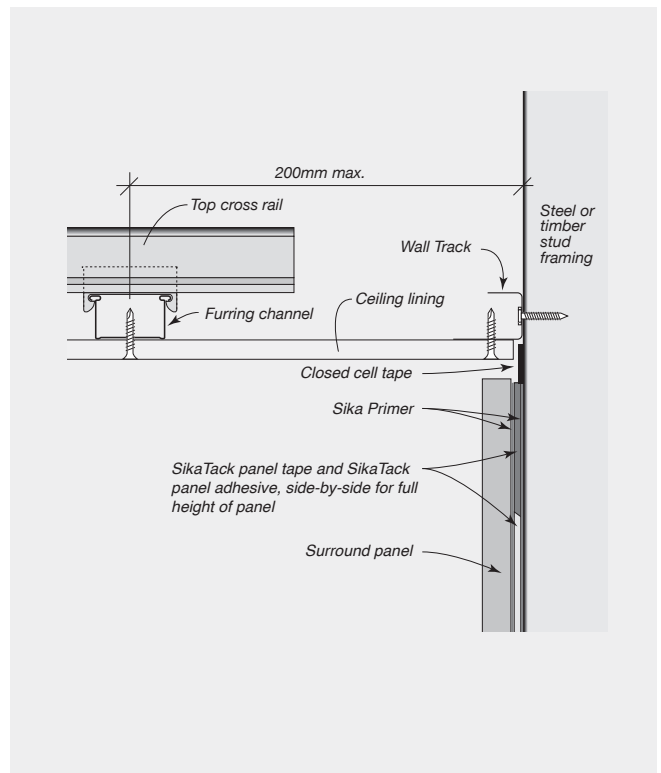

## CONSTRUCTION DRAWINGS AND DETAILS



Note: Drawings are interchangeable for timber or steel substrates with the exception of the fasteners.

**FIGURE 8.05** Obtuse Angle

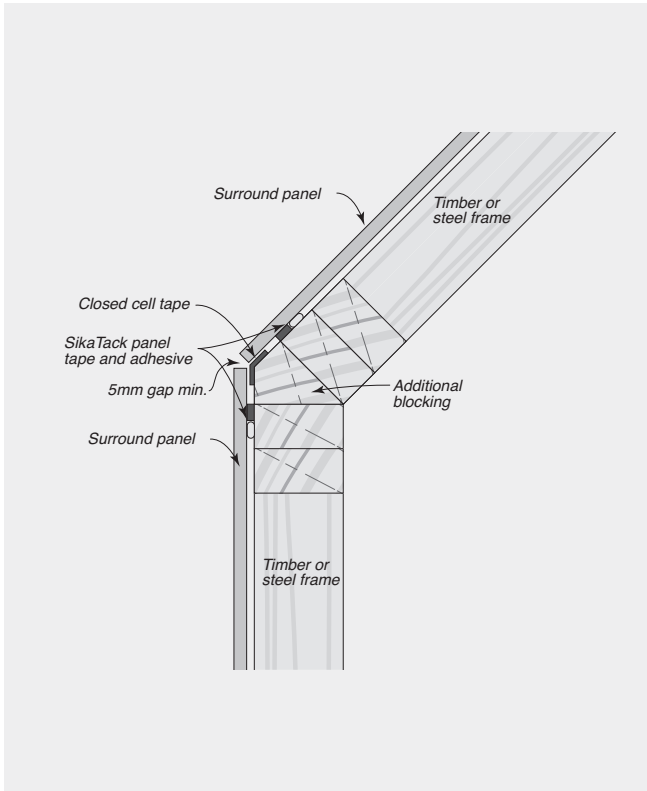

**FIGURE 8.06** External Corner

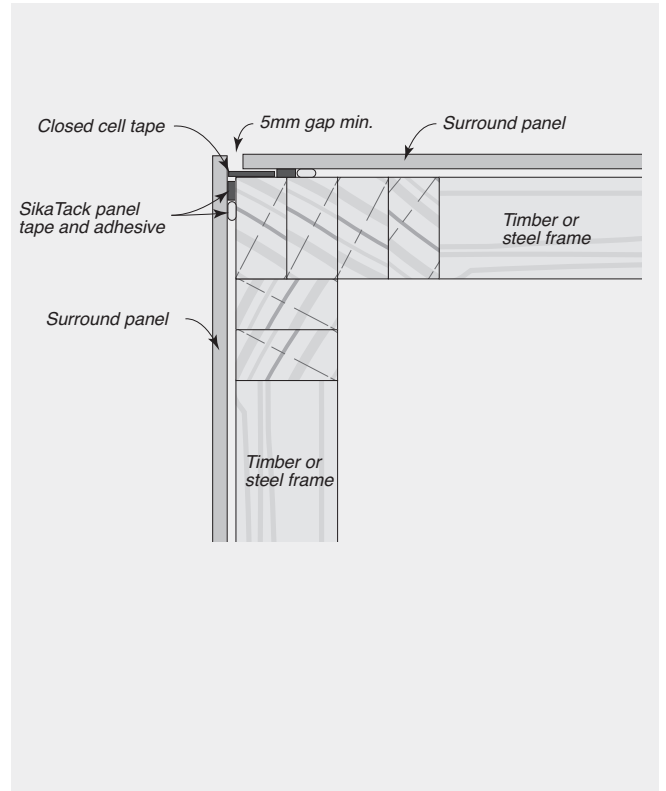

**FIGURE 8.07** Internal Corner

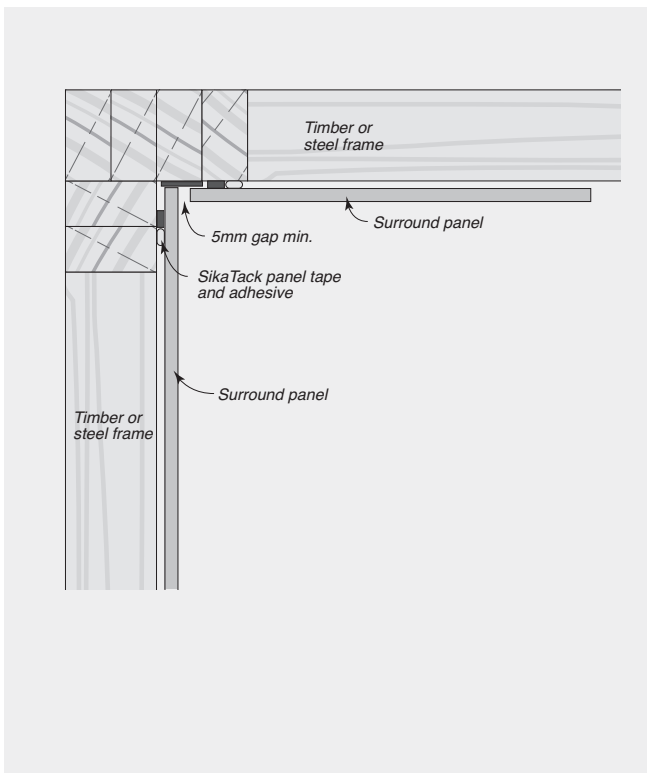



SAFETY, HANDLING, GENERAL CARE  
& WARRANTY



## SAFETY, HANDLING + GENERAL CARE



### Health, Safety and Personal Protection Equipment (PPE)

**Fibre Cement contain silicas that are harmful if inhaled. Protective clothing and breathing equipment should be worn when cutting products.**

When cutting, drilling or grinding fibre cement panels using power tools, always ensure the work area is properly ventilated.

An approved dust mask (AS/NZS 1715 and AS/NZS 1716) and safety glasses (AS/NZS 1337) must be worn. Cemintel recommends that hearing protection also be worn.

Safety Data Sheet information is available at [www.cemintel.com.au](http://www.cemintel.com.au)

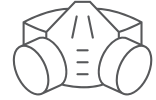

### Managing Respirable Crystalline Silica Dust

Crystalline Silica is everywhere. It is found naturally in stone, rocks, sand, gravel and clay. Sand is one of the raw materials in Fibre Cement. Respirable Crystalline Silica dust is the fine dust that's created when you use power tools to cut, drill, grind, chip or sand materials and products that contain crystalline

silica. This dust is of concern due to its size as it gets caught deep in your lungs and can cause long term damage.

IF YOU USE THE CORRECT SAFETY EQUIPMENT AND PPE, FIBRE CEMENT IS SAFE TO USE.

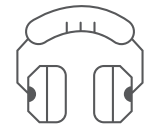

### Cemintel Safety Requirements

1 - Cut Outdoors*	The ventilation outdoors is greater than that indoors, and therefore should reduce exposure.
2 - Use On-Tool Dust Extraction	Use on-tool dust extraction when using power tools to drill and cut Fibre Cement, with a vacuum that contains a HEPA M Class filter.
3 - Correct Saw and Blade	Use a plunge saw with a specifically designed Fibre Cement blade.
4 - Don't Sweep, Vacuum instead	When completing your work vacuum with a HEPA M Class filter, rather than a broom as sweeping creates more dust.
5 - Use Correct Respirator	Use a half face P1 or P2 respirator. It is essential that the respirators are Fit Tested and workers are cleanly shaven to obtain a good seal.

\* Even though not recommended, indoor cutting can be completed when using an onsite cutting room with exhaust ventilation and a M class filter at a minimum, on-tool dust extraction with a vacuum with a HEPA M Class filter, a Full Face P2 respirator and conducting local occupational and static air monitoring to validate effectiveness of control measures.

## Safety, Handling, and Maintenance

### Storage

All Cemintel panels must be stacked flat, clear of the ground and supported at 300mm maximum centres on a level platform. Panels must be kept dry, preferably stored inside the building. Panels must be dry prior to fixing, hence if it is necessary to store outside, the product must be protected from the weather.

### Handling

Prefinished products and must be treated with care during handling to avoid damage to edges, ends and prefinished surface. Panels should be carried horizontally on edge by at least two people.

Consideration should be given to planning the order of other trades that might stain or damage the panels.

Any splashings of mud, cement, mortar and the like should be removed immediately.

### Warranty

Cemintel Surround panels have a product warranty of 10 years.

The full product warranty is available for download at [cemintel.com.au](http://cemintel.com.au)

### Cutting

Panels should be fully supported and cut from the back using a power saw. Cemintel recommends using the Makita Plunge Cut Saw with guide rail and appropriate blade, together with the appropriate dust extraction system. All exposed cut edges **MUST BE SEALED WITH CEMINTEL EDGE SEALER TO PREVENT MOISTURE ABSORPTION.**

### Mitres

It is not recommended to mitre panel edges as this can cause delamination of the face.

### Penetrations

Penetrations in panels may be cut or drilled prior to installation. Cut from the back or drill from the front. Mask, prime and fill gaps with sealant in accordance with recommended methods and products.

## NOTES

---

A large grid of small dots for taking notes, covering the majority of the page below the 'NOTES' header.

## NOTES

---

A large grid of small dots for taking notes, covering the majority of the page below the 'NOTES' header.



---

## Our Offices

### **Sydney**

376 Victoria Street  
Wetherill Park NSW 2164

### **Adelaide**

Lot 100 Sharp Court  
Mawson Lakes SA 5095

### **Darwin**

Cnr Stuart Highway  
& Angliss Street  
Berrimah NT 0828

### **Melbourne**

277 Whitehall Street  
Yarraville VIC 3013

### **Perth**

19 Sheffield Road  
Welshpool WA 6106

### **Brisbane**

768 Boundary Road  
Coopers Plains QLD 4108

### **Hobart**

11 Farley Street  
Derwent Park TAS 7009

**[cemintel.com.au](http://cemintel.com.au)**

1300 236 468

For Design and Technical Support:

**DesignLINK** – 1800 621 117

Cemintel is a trading entity of CSR Building Products Limited (ACN 008 631 356).

The products referred to in this document have been manufactured by or on behalf of CSR Building Products Limited ("CSR") to comply with the National Construction Code of Australia (NCC) and any relevant Australian Standards. While any design or usage guidelines set out in this document have been prepared in good faith by CSR, they are of a general nature only and are intended to be used in conjunction with project specific design and engineering advice.

It is the responsibility of the customer to ensure that CSR's products are suitable for their chosen application, including in respect of project-specific matters such as, but not limited to structural adequacy, acoustic, fire resistance/combustibility, thermal, and weatherproofing requirements. All information relating to design/installation/application of these products is offered without warranty and no responsibility can be accepted by CSR for errors and omissions, or for any use of the relevant products not in accordance with CSR's technical literature or any other relevant industry standards. For current technical and warranty documentation relating to Cemintel's products, visit Cemintel's website at [www.cemintel.com.au](http://www.cemintel.com.au).